

PACE PAL®



1594 Kings Carriage
Grand Blanc, Michigan 48439
Telephone: (810) 853-1159
E-mail: larry@mypacepal.com
Website: www.mypacepal.com

UNDERWATER PACE CLOCK INSTRUCTIONS

Thank you for buying the patented PACE PAL® Underwater Pace Clock. **Please read these instructions to get the most out of your purchase:**



DO NOT SUBMERGE CLOCK DEEPER THAN 10 FEET

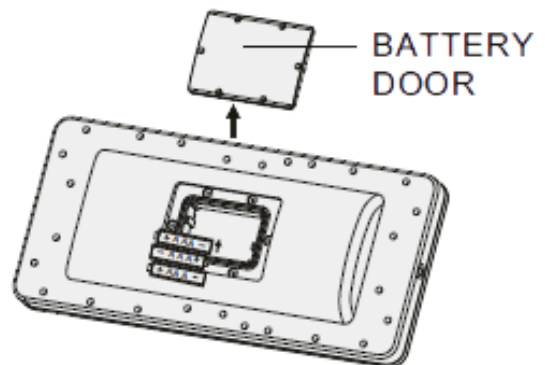
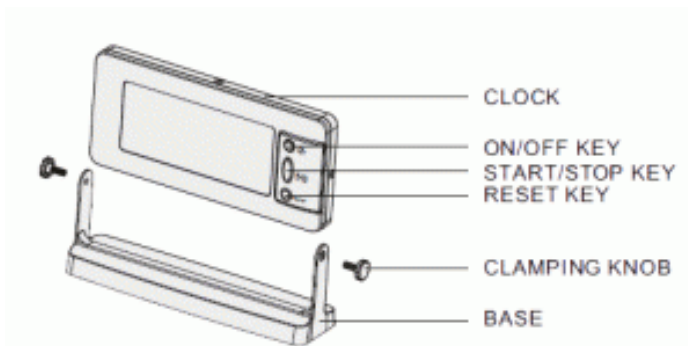

1. Batteries are *already installed* and should last 1 year or more. To replace, use a small (#0) philips-head screwdriver and remove the battery cover lid on the back of the clock. Put in three fresh AAA batteries. Then put a thin bead of silicone grease over the gasket. **PERMATEX DIELECTRIC GREASE (Item #81150)** can be purchased at AUTO ZONE and other auto parts stores. Evenly hand-tighten the battery screws around the lid perimeter while gently pressing down on the center of the lid. **DO NOT OVER-TIGHTEN OR THREADS MAY STRIP.**
2. Experience has taught us it is better to leave the clock running at all times. There is no need to “power off/on.” The battery life (1- 2 years) is not meaningfully shortened when the clock runs all the time and it is actually easier on the electronics. *When display numbers begin to fade, it's time to change the batteries.*
3. Clocks are normally shipped in the "on" (running) position, but if the display is blank, press the "on/off" button until you hear the "click" and digits will display.
4. Basic clock button functions are as follows:
 - a. Press upper round button “ON/OFF” once *if* you need to power up, show: 00:00. *This will probably not be necessary because we ship the clocks powered up and running. As stated above, it is better to always leave the clock “ON.”*
 - b. Press the center of the middle (oval) button “START/STOP” once to start counting, and “:” will flash.
 - c. Press the center of the middle (oval) button “START/STOP” once again to stop counting, icon “:” will stop flashing.
 - d. Press the lower round button “RESET” at any time to reset to 00:00.
 - e. Press upper round button “ON/OFF” and hold for 4 seconds *if* you want to power off to turn the screen blank.
 - f. Maximum count up is 99 minutes 59 seconds (99:59), then clock automatically starts counting up again from 00:00.
5. We recommend **PACE PAL®** clocks be taken out of the pool, rinsed with cool tap water and dried with a soft cloth between uses. This will increase the life of your **PACE PAL®**.
6. The set screw and rubber grommet on the top of the clock are for attaching underwater cameras. There is also a **GoPro Adapter** inside your case to attach your camera to the top of the clock.
7. Most swimmers and coaches prefer the clock on the pool bottom or, above water, on the deck. However, the enclosed rope lanyard provides an option for hanging the clock from a lane line.
8. The **double-sided silicone suction cup pad** is for use on the smooth bottom of turbulent flow-current swim spas. It is not needed in regular pools. **SEE SUCTION CUP PAD INSTRUCTIONS**, below.
9. Dispose of batteries properly. Never throw batteries in fire. Batteries may leak or explode.

SUCTION PAD INSTRUCTIONS FOR USING PACE PAL®.
IN FLOW-CURRENT SWIM SPAS

1. **Before** turning your pool current flow on gently press the enclosed **suction cup circle pad** onto your smooth vinyl liner, bottom mirror or any smooth surface so all the suction cups adhere.
2. Place the **base** of **PACE PAL®** (with attached display) on top of the suction cup circle pad and gently press down on the **base** so the suction cups adhere to the bottom of the **base**. **Please do not press down on the top or face of the display because the clock or bracket arms may break.** Turn the display face up to the angle you want and gently tighten thumb screws to lock in place.
3. **Now** turn your swim spa flow current motor on.
4. To pick the clock off the bottom, **first turn off your flow current motor** so you are not being tossed about. Then, holding the **base** of the clock (not the display), gently tilt it forward or backward until the suction cups release.
5. Make sure to remove the suction cup pad from the bottom of the pool so it does not come loose, float around, and get into your filtration system.
6. **WARNING** – We have not tested the suction cup pad on all liner materials and do not know if the interaction with chlorine could stain or discolor some liners. We recommend removing the suction cup along with the clock after each workout.

PLEASE CALL ME WITH ANY QUESTIONS before trying to “fix” the clock. (810) 853-1159.

Thank you,



Larry Day
President (Over-The-Hill U of Michigan Swimmer)
PACE PAL, LLC
www.mypacepal.com

Updated 2-14-15